



INSTALLATION INSTRUCTIONS

ONE-WIRE ALTERNATOR CONVERSION KIT

for GM Delcotron 10-SI Alternators

This kit converts an internally regulated GM Delcotron alternator (61 or 63 amp) to a one-wire unit. Please follow the steps outlined in these instructions to ensure the installation is correct.

Recommended Tools

- Shop manual for your vehicle
- Mechanics tool set with SAE and metric size sockets and combination wrenches
- Screwdriver set including slotted and Phillips screwdrivers

Installation Instructions

- 1) Disconnect the negative battery cable at the battery and remove the alternator from the vehicle. Consult the shop manual for the proper alternator removal procedure for your vehicle. Taking notes, pictures, and even making a video of the disassembly can be helpful when rebuilding the alternator and reinstalling it on the vehicle.
- 2) Scribe alignment marks on the front and rear halves of the alternator housing. This will aid in properly aligning the housings during reassembly.
- 3) Remove the four bolts that hold the two halves of the alternator housing together. Using a slotted screwdriver, carefully pry the front and rear housings apart. After separating the housings, remove the old brush holder springs and discard.

NOTE: The winding (stator) must remain in the rear housing!

- 4) Remove the three nuts holding the stator inside the rear housing. Pry the stator evenly from the rear case with a slotted screwdriver.

NOTE: Handle the stator carefully to avoid distorting the wires!

- 5) After removing the stator, remove the three screws holding the rectifier bridge, diode trio, voltage regulator, and brush holder to the rear housing. Two of the screws are insulated with plastic sleeves; the third screw is the ground and is not insulated.

NOTE: Mark the locations of each screw. Failure to reinstall screws in the proper location will prevent the alternator from functioning.

- 6) Install the new voltage regulator, then the new brush holder using one of the insulated screws and the non-insulated (ground) screw. Be sure the steel pin on the holder protrudes through the back of the housing.

NOTE: DO NOT remove the steel pin from the brush holder as it holds the brushes under tension!

- 7) Place the diode trio over the brush holder, and then install the rectifier bridge with the remaining insulated screw.
- 8) Place the stator in the rear housing by aligning the clearance notches on the stator with the bolt holes in the housing. Replace the three nuts. Make sure the terminals and wire leads are installed correctly into the housing without being grounded.
- 9) Reassemble the front and rear housings using the alignment marks made earlier as a guide. Replace the four bolts and tighten. Remove the steel pin that protrudes from the rear half of the alternator housing on the brush holder. This will allow the brushes to fall into position.
- 10) Reinstall the alternator onto the vehicle, then route one 10-gauge wire from the alternator terminal to the positive post of the battery.

(continued on back)

**One-Wire Alternator Conversion Kit
for GM Delcotron 10-SI Alternators**

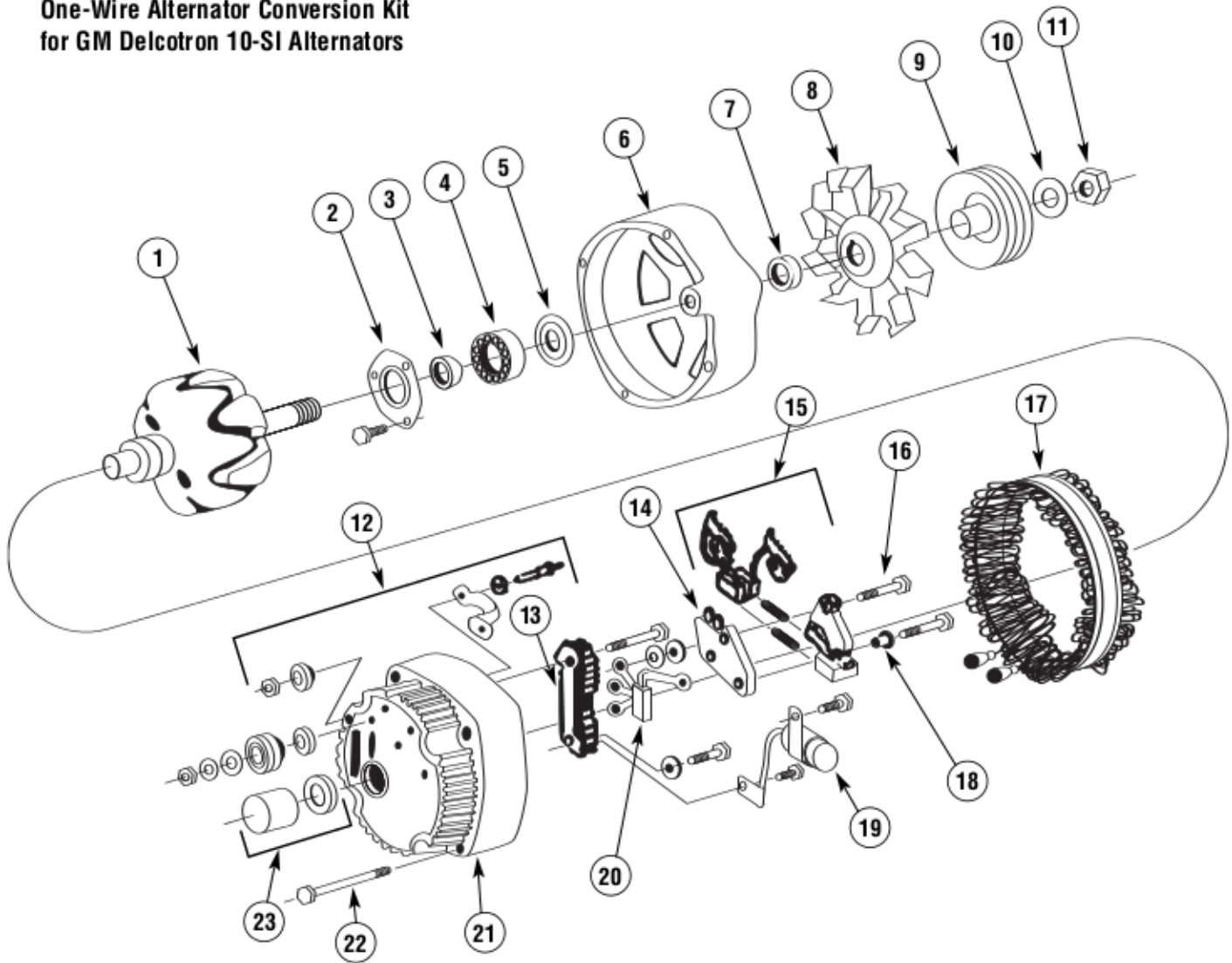

View No.	Description
1	61 Amp Rotor
2	Front Bearing Retainer
3	Inner Collar
4	Front Bearing
5	Shield
6	Front Housing
7	Outer Collar
8	Fan
9	Pulley
10	Lock Washer
11	Pulley Nut
12	Terminal Assembly
13	Rectifier Bridge

View No.	Description
14	Voltage Regulator
15	Brush Holder Assembly Brush Brush Holder Springs
16	#8 Screw
17	Stator (60 amp)
18	Insulating Washer
19	Capacitor
20	Diode Trio
21	Rear Housing
22	Thru Bolt #10
23	Rear Bearing